

Stichting Theaters Tilburg

Technical Specifications

Schouwburg



General Information

Address

City Tilburg
Theater Schouwburg Concertzaal Tilburg
Hall Schouwburg

Visiting Address & Parking
Performers entrance Louis Bouwmeesterplein 1
5038 TN Tilburg
[Location Performers entrance](#)

Loading Dock
Lift 1 Louis Bouwmeesterplein, Tilburg
[Location Trailerlift 1](#)

Lift 2 Kloosterstraat 6-2, Tilburg
[Location Trailerlift 2](#)

Phone numbers

General 013 5490 390
Ticket service 013 5432 220

Contact information

Contact Technical department Bas van Steen 013 5490 341
Ineke Padmos 013 5490 327
techniek@schouwburgconcertzaaltilburg.nl

Contact Production Anne Rosenau 013 5490 316
arosenau@schouwburgconcertzaaltilburg.nl

Standard times

Lunch 12:30 – 13:00
Dinner 17:00 – 19:00

Evening showtime 20:15
Showtime matinee variable

Fire alarms can be turned off, but always in consultation with the technicians of Schouwburg Concertzaal Tilburg

Accessibility

The main entrances of the Schouwburg, Concertzaal and Studio are located on the Schouwburgring. The coordinating address and the backstage entrance is Louis Bouwmeesterplein 1, 5038 TN Tilburg.

Parking

The municipality of Tilburg does not provide free parking around the theatre. There are multiple paid car parks around Schouwburg Concertzaal Tilburg. Parking can be paid with cash or by debit- or credit card.

Please take into account that Thursday evenings are extra busy due to extended opening hours of stores in the city centre. Parking takes considerably more time than on other days. Extra crowds can also be expected on Sundays and holidays.

Public transport

Tilburg Central station is located 15 minutes from the theatre. It also an option to take a city taxi or a bus.

Loading dock

To be able to load and unload trucks, two lifts are used to lift trucks up to stage level.

Max. length trucks: 18m

At its smallest, the passage to the stage is 3m wide and 6m high

[Location lift 1](#)

[Location lift 2](#)

Technical general information

Venue capacity

Total	860
Floor level, incl. orchestra pit	544
orchestra pit	39
1° Balcony	169
2° Balcony	164
Standard amount of FOH places	16 (2x8) <i>Other numbers in consultation</i>

Soft furnishings and details

Stage floor	Material	Keroewing Hardwood
	Thickness	28mm - 500 kg/m2
Marley	Colour	black
	Width	1.60m per lane
House curtain	Colour	Red/green
	Operation	Stage Left, manual
	Way of Opening	Traveler

Soft goods and masking

General	Colour	Night Blue
12x leg	Height	10.00 meter
	Width	05.50 meter
5x border	Height	04.00 meter
	Width	21.00 meter
1x border	Height	06.00 meter
	Width	21.00 meter
3x full black <i>Consists out of 12 extra legs</i>	Height	10.00 meter
	Width	20.00 meter
2x side blacks <i>Consists out of 6 short legs</i>	Height	09.00 meter
	Width	13.50 meter
2x side blacks <i>Consists out of 4 pieces on a rails, attached permanently</i>	Height	09.00 meter
	Width	02.00 meter
Cyclorama	Height	10.00 meter
	Width	21.00 meter
Black gauze	Height	09.00 meter
	Width	16.00 meter
Opera foil	Height	08.00 meter
	Width	16.00 meter

Dimensions

Stage dimensions

Proscenium	Height		08.70	meter
	Width		13.70	meter
Portal	Height	Min.	00.00	meter
		Max.	08.15	meter
	Width	Min.	10.00	meter
		Max.	15.80	meter
Stage floor	Width		21.00	meter
		<i>Including wing space</i>	34.00	meter
Zero to rear wall	Depth		12.00	meter
Edge of the apron to rear wall	Depth		15.00	meter
Edge of the orchestra pit to rear wall	Depth		18.00	meter

Distances from zero

Edge of the apron		-03.00	meter
Rear wall		14.70	meter
Backwall auditorium		-19.60	meter
House curtain		-01.51	meter
Proscenium fly bar		-01.26	meter
Portal		-0.79	meter
Backside safety curtain		-1.78	meter

Heights relative to stage floor

Fly loft		20.70	meter
Maximum fly bar height		19.70	meter
Side bridges	Min.	1.00	meter
	Max.	12.00	meter

Orchestra facilities

Orchestra pit

The orchestra pit is variable in height between the orchestra pit level and the stage. The pit exists out of a fixed room beneath the stage and a moving part in the auditorium

The orchestra pit is accessible via 2 doors, left and right through normal sized doors and a small set of stairs. Instruments can be brought to the orchestra pit from ground level and stage level. For the dimensions of the orchestra pit, see the floorplan on the website.

A conductor camera is available.

Orchestra facilities

Conductor riser	1x	100 x 100 cm, variable height, including conductor stand
Orchestra chairs	55x	Without armrests
Music stands	45x	Adjustable height
Reading lights	45x	For music stands

Fly system

The fly system is computer controlled with a TNM system by the manufacturer Trekwerk. All flybars except the flybars in the auditorium and 2 flybars underneath the side bridges are connected to this system. The loading capacity of the system is assessed according to the NPR8020-10 with a safety factor of 10 (hoists above persons)

The SWL/WLL on all lifting materials must therefore be halved. All hoisting equipment of Schouwburg Concertzaal Tilburg is rated with a factor 10. Rigging and hanging of loads is only permitted with certified equipment. Such is all at the discretion of the on duty fly bar operator of Schouwburg Concertzaal Tilburg.

The fly system can only be controlled by a qualified operator from Schouwburg Concertzaal Tilburg.

Fly bars

59 fly bars

Max. Height 19.70 meter

Min. Height 00.05 meter

Fly bar length 21.00 meter

Max. Speed 1.7 m/s

Distance between fly bars 20 cm (with the exception of fly bars 02, 20, 38, 56, due to steel beams 30-35 cm distance)

Distance between zero to 1st fly bar is 00.38 meter.

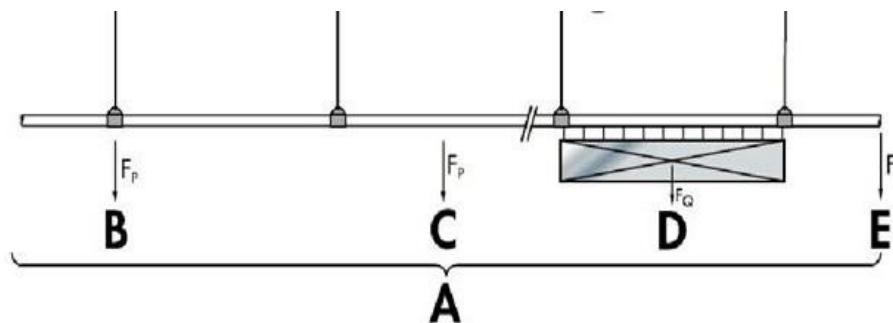

Max. load, see below.

	A	B	C	D	E
Fly bars	500 kg	250 kg	250kg	300Kg	75 kg
Proscenium fly bar	500 kg	250 kg	250kg	300Kg	75 kg
Side fly bars	500 kg	250 kg	250kg	300Kg	75 kg

Side fly bars

6 side fly bars;

2 on the inside of the side bridges, fly bar length 12.50m;

2 on the outside of the side bridges, fly bar length 11.50m; max. load see table above.

2 side bars underneath side bridges, not controlled by the fly system. Max. load is 300 kg

Proscenium fly bar

Flybar length 19.00 meter
Max. speed 1.7 m/s
Distance to zero -01.26 meter
Max. load see table above

Auditorium fly bars

The auditorium flybars are mainly used for audio rigging.
1 left , fly bar length 2m, max load 500 kg
1 centre, fly bar length 2m , max load 300 kg
1 right, fly bar length 2m , max load 500 kg

There is also 1 fly bar located underneath the first FOH bridge.
Max. load is 300kg with equal load, 150kg point load.

Point hoists

12 point hoists (chain hoists)
4 areas which can all contain a maximum of 3 hoists.
Max. load is 500kg
Max. height is 20m
Min. height 0m

Electrics and infrastructure

Power distribution

All high voltage current connections have CEE-norm red connectors, with 3 phases, zero and ground

125A	1x	Stage left, downstage
	1x	Stage right, downstage
	1x	Stage right, centre stage
63A	2x	Stage right, centre stage
32A	2x	Stage right, centre stage
	1x	Stage right, down stage (audio)
	1x	Stage left, centre stage (16 A fuse)
	1x	Stage left, downstage (audio)
	1x	Side bridge stage right
	1x	Side bridge stage left
220V 16A		Multiple points, CEE and wall sockets

DMX

The DMX- network is installed as a star-network, of which the middle is located at stage left, downstage. DMX can be sent and received at multiple locations throughout the venue.

Network

The venue also has an extensive CAT7 network. Multiple lines for audio, video and sACN are located throughout the venue.

LED conversion

The LED fixtures in the 2nd FOH and in the proscenium can be controlled with one channel. For the Cyclorama 4 colours are available. Each light can be programmed with any colour desired by the visiting company.

If desired, It is also possible to control the LED fixtures in their full mode with sACN. For a current patch list, contact our technical department at techniek@schouwburgconcertzaaltilburg.nl

Lighting

Lighting console

Roadhog 4,
Faderwing available in consultation

Prerigged fixtures

1st FOH	20x	Altman 2kW zoomprofile
2nd FOH	12x	ETC Source4 LED Tungsten HD 14°
Portal	12x 8x	Altman 1kW zoomprofile 12°-40° ADB C101 1kW PC
Side bridges (per side)	10x	Altman 2kW zoomprofile 12°-40°
Proscenium (per side)	3x	ETC Source4 LED Tungsten HD 15°-30°
Side of the portal (per side)	6x	Altman 1kW zoomprofile 12°-40°
Cyclorama	14x	Robert Juliat Dalis 860
Follow spot	2x	Robert Juliat Victor 1800W MSR
House lights		Led fixture, divided in 3 groups
Curtain warmers	4x	ADB C51 500W PC, from 1 st FOH
Conductor lights	2x	Altman 2kW zoomprofile, from proscenium (fixed position)
Orientation lights		Stage Left, Stage Right and upstage

Extra fixtures

Pars	24x	ETC Source4 MultiPAR 750W; WFL, MFL, NSP, VNSP
	6x	6-bar ETC Source4 MultiPAR 750W; WFL, MFL, NSP, VNSP
PC	16x 16x	ADB 1kW C103 met barndoors ADB 2kW C201 met barndoors
Zoom profile	16x	Altman 1kW zoomprofile 12°-40°
Fresnell	8x	Desisti 2kW Leonardo
Flood	8x	Floodlight

*In consultation with
other halls*

LED profile	12x	ETC Source4 LED Lustr+ 25°-50°
LED strip	12x	Showtec Pixelbar 18 Q4
Movingheads		
Spot	8x	GLP Impression S350 profile
Wash	8x	Clay Paky K10 B-Eye
	24x	Prolights Astra Wash 7Pix

Risers

Risers	40x	200x100 cm
	2x	100x100 cm
Legs	60x	20 cm (15 risers)
	60x	40 cm (15 risers)
	48x	60 cm (12 risers)
	36x	80 cm (9 risers)
	36x	100 cm (9 risers)
Stairs	2x	20, 40, 60 en 80 cm
Masking		20, 40, 60, 80 en 100 cm
Fall prevention		Multiple lengths and amounts
Fences	14x	95 cm high, 200 cm wide
	10x	95 cm high, 100 cm wide

Audio

System

Meyer Sound (controlled actively)

Main		Meyer M'elody; auditorium fly bars stage left and right Meyer CQ1 en 600-HP; apron left and right
Center		Meyer UPA; centre auditorium fly bar
Infill		Meyer UPM-2P; stage left and right Meyer UPM-2P; front fill on the apron stage left and right
DSP		Galileo 616 processor

Monitors

Monitors	4x	D&B MAX12
Amplifiers	2x	D&B D6 Amplifiers

Multi-cable

Analog	36 ch.	Harting HAN108 audio FOH position auditorium 36x XLR Stage left and right 36x XLR in the control booth
Digital	Cat7	Ethernet Cat7 connection, assigned to D-rack

Consoles

Digico	SD11 / SD9	The use of our consoles is always in consultation and depends on the availability in our other halls.
D-rack		Located on stage right

Extra material

Schouwburg Concertzaal Tilburg has, in addition to the standard systems in our halls, an extensive collection of consoles, mics, wireless transmitters, monitors and other supplies and cables. These can be used in consultation with our other halls. For information and availability reach out to our technical department, via techniek@schouwburgconcertzaaltilburg.nl

Video

Schouwburg Concertzaal Tilburg has multiple audiovisual supplies, which contain beamers, laptops and mixing devices. Availability is always in consultation with our other halls. For information and availability reach out to our technical department, via techniek@schouwburgconcertzaaltilburg.nl

Piano

Grand Piano	Steinway B	Serienr. 524797
--------------------	------------	-----------------

Piano	Seiler	Serienr. 160630
--------------	--------	-----------------

The grand piano is always available, piano only upon request.

Dressing rooms

Stage level	5x	Ladies and men's toilets, connection for 3 washing machines and dryers, elevator to ground level
--------------------	----	--

Dressing room 3

2-4 persons, adapted disabled toilet

Dressing room 4,5 and 6

2-4 persons, shower, sink

Dressing room 7

6-10 persons, sink

Ground level	3x	Ladies and men's toilets, 4 showers
---------------------	----	-------------------------------------

Dressing room 9

4-8 persons, sink

Dressing room 10

12-25 persons, sinks

Dressingroom 11

12-25 persons, sinks

An audio feed of the auditorium and public address system are available from stage left and control booth.

Green room

Shared with the Studio.

Space for 50 persons, seating for 36 persons.

Analog tv feed, monitor with feed from the stage.

Small audio installation, mic available

An audio feed of the auditorium and public address system are available from stage left and control booth.

There is someone from our hospitality department available in the green room from the moment the artists arrive, until after intermission. Other times are in consultation with our hospitality department.

Information for catering or about the green room:

- Carla Donkers, cdonkers@schouwburgconcertzaaltilburg.nl
013 5490 308 (Corporate)
- Anne Rosenau, arosenau@schouwburgconcertzaaltilburg.nl
013 5490 316 (impresario's)